









# BLACK DIAMOND<sup>TM</sup>

## SMART-FR CHARGE *System*<sup>TM</sup>

### Installation and User Manuals



Document ID	0XMACA00010000UGE3	5833 Orr Road Charlotte, NC 28213 P: 877-914-8999 F: 540-982-4287 <a href="http://www.GECIproducts.net">www.GECIproducts.net</a>
Revision number	001	
Revision date	January 2022	
 English 'Original instructions'		

 English 	 Français 	 Deutsch 	 Italiano 
---	--	--	--

# TABLE OF CONTENTS

**0. INTRODUCTION ..... 2**

**1. IMPORTANT SAFETY INSTRUCTION ..... 2**

**2. INSTALLATION..... 5**

**3. OPERATION.....15**

**4. CONTROL BOARD ALARMS AND TROUBLESHOOTING .....18**

## 0. INTRODUCTION

This manual contains important safety instructions, cautions and warnings, to be followed by qualified personnel responsible for the installation, maintenance and operation of battery chargers.

We recommend this manual to be read and understood entirely, to ensure safe and reliable operation of this equipment. Inspect and understand all warning labels located on the charger. Order and replace labels if they cannot be easily read.

In case of doubts, please contact our service department.

Keep printed and electronic copies of this manual readily available for future needs. Please contact our service department if you need a new copy.

## 1. IMPORTANT SAFETY INSTRUCTION

### 1.1 IMPORTANT SAFETY INSTRUCTION

(a) THIS MANUAL CONTAINS IMPORTANT SAFETY AND OPERATING INSTRUCTIONS

(b) WORKING IN THE VICINITY OF A LEAD-ACID BATTERY IS DANGEROUS. BATTERIES GENERATE EXPLOSIVE GASES DURING NORMAL BATTERY OPERATION. FOR THIS REASON IT IS OF THE UTMOST IMPORTANCE THAT EACH TIME BEFORE USING YOUR CHARGER, YOU READ AND FOLLOW THE INSTRUCTIONS PROVIDED EXACTLY

(c) TO REDUCE RISK OF BATTERY EXPLOSION, FOLLOW THESE INSTRUCTIONS AND THOSE MARKED ON THE BATTERY

(d) NEVER SMOKE OR ALLOW AN OPEN SPARK OR FLAME IN THE VICINITY OF THE BATTERY OR ENGINE

(e) USE CHARGER FOR CHARGING A LEAD-ACID BATTERY ONLY. IT IS NOT INTENDED TO SUPPLY POWER TO AN EXTRA-LOW-VOLTAGE ELECTRICAL SYSTEM OR TO CHARGE DRY-CELL BATTERIES. CHARGING DRY-CELL BATTERIES MAY CAUSE THEM TO BURST AND CAUSE INJURY TO PERSONS AND DAMAGE TO PROPERTY

(f) NEVER CHARGE A FROZEN BATTERY

(g) IF IT IS NECESSARY TO REMOVE BATTERY FROM VEHICLE TO CHARGE IT, ALWAYS REMOVE GROUNDED TERMINAL FROM BATTERY FIRST. MAKE SURE ALL ACCESSORIES IN THE VEHICLE ARE OFF IN ORDER TO PREVENT AN ARC

(h) STUDY ALL BATTERY MANUFACTURER'S SPECIFIC PRECAUTIONS SUCH AS REMOVING OR NOT REMOVING CELL CAPS WHILE CHARGING AND RECOMMENDED RATES OF CHARGE

(i) FOR A CHARGER HAVING AN OUTPUT VOLTAGE SELECTOR SWITCH, REFER TO THE CAR OWNER'S MANUAL IN ORDER TO DETERMINE THE VOLTAGE OF THE BATTERY AND TO MAKE SURE THE OUTPUT VOLTAGE IS SET AT THE CORRECT VOLTAGE. IF AN OUTPUT VOLTAGE SELECTOR SWITCH IS NOT PROVIDED, DO NOT USE THE BATTERY CHARGER UNLESS THE BATTERY VOLTAGE MATCHES THE

## OUTPUT VOLTAGE RATING OF THE CHARGER

(j) NEVER PLACE THE CHARGER DIRECTLY ABOVE OR BELOW THE BATTERY BEING CHARGED; GASES OR FLUIDS FROM THE BATTERY WILL CORRODE AND DAMAGE THE CHARGER. LOCATE THE CHARGER AS FAR AWAY FROM THE BATTERY AS DC CABLES PERMIT

(k) DO NOT OPERATE CHARGER IN A CLOSED-IN AREA OR RESTRICT VENTILATION IN ANY WAY

(l) CONNECT AND DISCONNECT DC OUTPUT CLIPS ONLY AFTER SETTING ANY CHARGER SWITCHES TO THE OFF POSITION AND REMOVING AC CORD FROM THE ELECTRIC OUTLET. NEVER ALLOW CLIPS TO TOUCH EACH OTHER

(m) FOLLOW THESE STEPS WHEN BATTERY IS INSTALLED IN VEHICLE. A SPARK NEAR BATTERY MAY CAUSE A BATTERY EXPLOSION. TO REDUCE RISK OF A SPARK NEAR BATTERY:

-(m.1) POSITION AC AND DC CORDS TO REDUCE RISK OF DAMAGE BY HOOD, DOOR, OR MOVING ENGINE PART;

-(m.2) STAY CLEAR OF FAN BLADES, BELTS, PULLEYS, AND OTHER PARTS THAT CAN CAUSE INJURY TO PERSONS;

-(m.3) CHECK POLARITY OF BATTERY POSTS. A POSITIVE (POS, P, +) BATTERY POST USUALLY HAS A LARGER DIAMETER THAN A NEGATIVE (NEG, N, -) POST;

-(m.4) DETERMINE WHICH POST OF BATTERY IS GROUNDED (CONNECTED) TO THE CHASSIS. IF NEGATIVE POST IS GROUNDED TO CHASSIS (AS IN MOST VEHICLES), SEE ITEM (v). IF POSITIVE POST IS GROUNDED TO THE CHASSIS, SEE ITEM (m.6);

-(m.5) FOR A NEGATIVE-GROUNDED VEHICLE, CONNECT THE POSITIVE (RED) CLIP FROM BATTERY CHARGER TO POSITIVE (POS, P, +) UNGROUNDED POST OF BATTERY. CONNECT THE NEGATIVE (BLACK) CLIP TO VEHICLE CHASSIS OR ENGINE BLOCK AWAY FROM BATTERY. DO NOT CONNECT CLIP TO CARBURETOR, FUEL LINES, OR SHEET-METAL BODY PARTS. CONNECT TO A HEAVY GAUGE METAL PART OF THE FRAME OR ENGINE BLOCK;

-(m.6) FOR A POSITIVE-GROUNDED VEHICLE, CONNECT THE NEGATIVE (BLACK) CLIP FROM BATTERY CHARGER TO NEGATIVE (NEG, N, -) UNGROUNDED POST OF BATTERY. CONNECT THE POSITIVE (RED) CLIP TO VEHICLE CHASSIS OR ENGINE BLOCK AWAY FROM BATTERY. DO NOT CONNECT CLIP TO CARBURETOR, FUEL LINES, OR SHEET-METAL BODY PARTS. CONNECT TO A HEAVY GAUGE METAL PART OF THE FRAME OR ENGINE BLOCK;

-(m.7) CONNECT CHARGER AC SUPPLY CORD TO ELECTRIC OUTLET;

-(m.8) WHEN DISCONNECTING CHARGER, TURN SWITCHES TO OFF, DISCONNECT AC CORD, REMOVE CLIP FROM VEHICLE CHASSIS, AND THEN REMOVE CLIP FROM BATTERY TERMINAL

(n) FOLLOW THESE STEPS WHEN BATTERY IS OUTSIDE VEHICLE. A SPARK NEAR THE BATTERY MAY CAUSE A BATTERY EXPLOSION. TO REDUCE RISK OF A SPARK NEAR BATTERY:

-(n.1) CHECK POLARITY OF BATTERY POSTS. A POSITIVE (POS, P, +) BATTERY POST USUALLY HAS A LARGER DIAMETER THAN A NEGATIVE (NEG, N, -) POST;

-(n.2) ATTACH AT LEAST A 60 CM 6-GAUGE (AWG) INSULATED BATTERY CABLE TO A NEGATIVE (NEG, N, -) BATTERY POST;

-(n.3) CONNECT THE POSITIVE (RED) CHARGER CLIP TO THE POSITIVE (POS, P, +) POST OF BATTERY;

-(n.4) POSITION YOURSELF AND THE FREE END OF CABLE AS FAR AWAY FROM BATTERY AS POSSIBLE, THEN CONNECT THE NEGATIVE (BLACK) CHARGER CLIP TO FREE END OF CABLE;

-(n.5) DO NOT FACE BATTERY WHEN MAKING FINAL CONNECTION;

-(n.6) CONNECT CHARGER AC SUPPLY CORD TO ELECTRICAL OUTLET;

-(n.7) WHEN DISCONNECTING CHARGER, ALWAYS DO SO IN REVERSE SEQUENCE OF CONNECTING PROCEDURE AND BREAK FIRST CONNECTION WHILE STANDING AS FAR AWAY FROM BATTERY AS

## PRACTICAL

(o) USE OF AN ADAPTER IS NOT ALLOWED IN CANADA. IF A GROUNDING TYPE RECEPTACLE IS NOT AVAILABLE, DO NOT USE THIS APPLIANCE UNTIL THE PROPER OUTLET IS INSTALLED BY A QUALIFIED ELECTRICIAN

(p) CERTIFIED DC OUTPUT CONNECTOR, SUFFICIENTLY RATED IN VOLTS AND AMPERES, SHALL CONNECTED TO FREE ENDS OF OUTPUT CABLE WITH ATTENTION TO MARKED POLARITY

## 1.2 IMPORTANT NOTES

- Only experienced and qualified personnel, knowledgeable on batteries and safety requirements involved, most perform installation and maintenance.
- Installation and wiring must comply with all the applicable local and the national electrical codes.
- Protection devices as fuses or circuit breakers, must be located on the AC mains where the charger is connected. Check the product nameplate for voltage and phase requirements.  
This charger can only charge motive power batteries of flooded lead-acid type. Strictly follow all setup and operating instructions to prevent damage to the battery and hazardous conditions.

**DANGER! High Voltage**

- Dangerous AC and DC voltages and currents are present in these systems even when external indicators and LEDs are completely off. Before performing any maintenance, make sure that the AC power and battery are disconnected.

**DANGER! Explosive Gases**

- Lead-Acid batteries generate an explosive mixture of oxygen and hydrogen during the normal charging process. Never smoke or allow sparks or flames in the vicinity of batteries. Ensure a sufficient ventilation to prevent explosive gases buildup.

**DANGER! Corrosive Substances**

- Lead-Acid batteries contain a sulfuric acid ( $H_2SO_4$ ) solution, which is capable of causing very severe skin burns and can induce permanent blindness if splashed onto eyes. Always wear correct eye and body protection when near batteries. In case of contact with eyes, flush immediately with clean water for at least 15 minutes, and seek professional medical attention immediately.



**DANGER! High Temperature**

- The internal parts of the machine are not accessible during normal operation. To access these parts it is necessary to open the front and / or rear doors, closed by screws. Avoid prolonged contact with hot surfaces could cause discomfort or burns. Keep this in mind if you have a physical condition that affects your ability to feel heat on your skin.
- The weight of battery chargers can crush hands and feet if care is not taken when installing and handling them. Use adequate handling equipment and install chargers in a stable location.
- This charger has been designed for indoor use only. It must be installed in a well ventilated, cool, dry and clean place. Do not expose to rain, snow, moisture, dust and corrosive substances.
- To reduce the risk of fire, install chargers on a floor of non-combustible material.
- Never place the charger directly above or below the battery being charged; gases or fluids from the battery may damage the charger. Locate the charger as far away from the battery as DC cables permit.
- The shipping pallets and all packaging materials must be removed for proper and safe operation.
- Do not block the ventilation openings of the charger.
- Do not install or operate charger if it has been dropped during transport or damaged in any way.
- Never charge a frozen battery.
- Inspect AC and DC cables for damage to the insulation. Replace damaged cables immediately, with cables of the same type and length. Do not extend the DC charging cables, as it may cause improper operation of the charger, and damage the battery.
- The manufacturer is not responsible and the warranty is void if the product is damaged due to negligence, abuse, misuse, accident, modification, alteration, tampering and faulty installation.

2. INSTALLATION



**CAUTION!**

The charger can be installed, configured and serviced by qualified personnel only



**CAUTION!**

Read and understand Chapter 2 “Important Safety Instructions” before installing, configuring, servicing or using the charger.

PRELIMINARY INSPECTION

- Unbox the charger and remove all packaging materials.
- Inspect the unit for potential damages, loose screws and missing parts.
- Ensure that the ventilation openings are not obstructed.

## OPERATING CONDITIONS

Storage Temperature: -25°C to 55°C  
 Operating Temperature: -25°C to 40°C  
 Humidity: 0% to 70%

The charger has been designed for indoor use only. It must be installed in a well ventilated, cool, dry and clean place. Do not expose to rain, snow, moisture, dust and corrosive substances.

To reduce the risk of fire, install chargers on a floor of non-combustible material.

## INSTALLATION OF DC OUTPUT PLUG

Certified DC Output connector, sufficiently rated in volts and amperes, must be installed in the field by a qualified technician.

## INSTALLATION OF AC INPUT CABLE and PLUG

Depending on the applicable local regulations and the electrical ratings of the chargers, certain units are supplied with AC input cable & plug included (plug-in models) and others are supplied without AC input cable and/or plug (cord connected models).

In cord-connected models, the AC input cable and plug should be installed by a qualified electrician, in accordance to the local and national electrical code, together with the proper fuses, breakers and disconnect switches.

## 1-PHASE MODEL LIST

<b>Ratings</b>	<b>Max. Input Power [VA]</b>	<b>Where VV of the series code representing the Output voltage [V] can be</b>	<b>Where AAA of the series code representing the Output current [A] can be</b>
1x120Vac 1x208Vac, 1x230Vac, 1x240Vac, 1x208/240Vac 1x480Vac 1x208/240/480Vac single phase 60 Hz, Max. Current 50A.	1500	12	40, 60, or 80
	6700	24	30, 40, 50, 60, 80, 100, 120, 140, 160 or 180
	10100	36	30, 40, 50, 60, 80, 100, 120, 140, 160 or 180
	13500	48	30, 40, 50, 60, 80, 100, 120, 140, 160 or 180
	9000	72	40, 60, or 80
	10000	80	40, 60 or 80

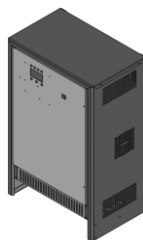

T9 cabinet mm (inches)  
 L496 (19.53) x W304 (11.97) x H783 (30.83)

### 3-PHASE MODEL LIST

<b>Ratings</b>	<b>Max. Input Power [VA]</b>	<b>Where VV of the series code representing the Output voltage [V] can be</b>	<b>Where AAA of the series code representing the Output current [A] can be</b>
3x208Vac, 3x240Vac 3x208/240Vac, 3x480Vac 3x208/240/480Vac, 3x600Vac, 3x480/600Vac, <b>three phases, 60 Hz, Max Current 50 A.</b>	2200	12	40, 60, 80, 100 or 120
	7500	24	60, 80, 100, 120, 140, 160, 180 or 200
	11200	36	60, 80, 100, 120, 140, 160, 180 or 200
	15000	48	60, 80, 100, 120, 140, 160, 180 or 200
	13500	72	40, 60, 80, 100 or 120
	15000	80	40, 60, 80, 100 or 120

### INPUT VOLTAGE SETTINGS

The battery chargers are equipped with two adjustment blocks for AC input nominal voltage selection and charging curve optimization.

1. **NOMINAL VOLTAGE SELECTION 3-phase**  
 This setting is present on chargers designed to operate at different nominal AC input voltages, for specs. 3x230/400 VAC, 3x208/240/480 VAC or 3x480/600 VAC (North American specs).  
 A screw type terminal block is used for this setting in certain chargers, while a bar-type (delta-wye) standard terminal block is used in other chargers.
  
2. **NOMINAL VOLTAGE SELECTION 1-phase**  
 This setting is present on chargers designed to operate at different nominal AC input voltages, for specs 1x230 VAC, 1x208/240VAC or 1x208/240/480 VAC (North American specs).  
 A screw type terminal block is used for this setting in certain chargers, while a bar-type (delta-wye) standard terminal block is used in other chargers.
  
3. **CHARGING CURVE OPTIMIZATION**  
 This setting is present on all chargers, and it's intended to compensate for AC input voltage fluctuations at the installation place.  
 It is recommended to check the actual value of the available AC input voltage at the installation site, and adjust the output current of the charger accordingly.  
 A screw type terminal block is used for this setting in all chargers: a single wire needs to be moved in single-phase models, and 3 wires need to be moved in three-phase models.

### RECOMMENDED OPERATING SEQUENCE

- Disconnect the charger from the AC input and from the battery.
- Measure the AC input voltage, using an adequate voltmeter.
- Open the cabinet or the front door of the charger.
- Find the terminal blocks for **NOMINAL VOLTAGE SELECTION** and **CHARGING CURVE OPTIMIZATION**.
- Make the necessary adjustments at the **NOMINAL VOLTAGE SELECTION** section.
- Make the necessary adjustments at the **CHARGING CURVE OPTIMIZATION** section.
- Double check that all connections are properly tightened.
- Close the cabinet or the front door of the charger.
- Connect the charger to the AC input.
- Connect the battery to the charger and verify the correct operation, by measuring the DC output current and DC output voltage.

## 2.1 INSTALLATION 3-phase 3x230/400Vac 50/60Hz

### 2.1.1 NOMINAL VOLTAGE SELECTION

Remove screws from the top and left/right sides in order to open the top cover of the charger.  
 If the charger model is designed for AC Multi Input. Please set the internal terminal board according to the nominal AC Mains provided from the grid

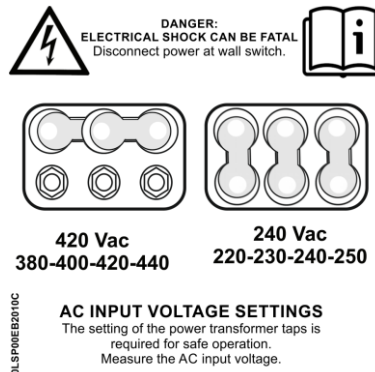

AC Mains  
 380-400-420-440 Vac

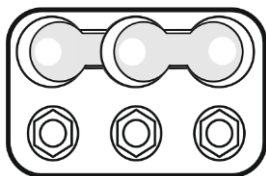

AC Mains  
 220-230-240-250 Vac

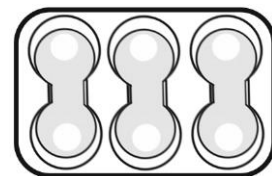

### 2.1.2 CHARGING CURVE OPTIMIZATION

Please set the internal adjust terminal block with correct AC voltage setting according to AC voltage detect in the AC input line

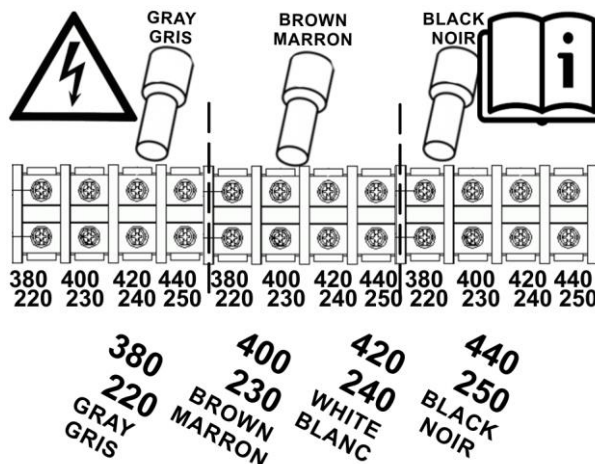

**AC INPUT VOLTAGE ADJUSTMENT**  
 The adjustment of the power transformer taps is required for safe and efficient operation. Measure the AC input voltage and adjust the setting accordingly.

0LSP00EB2010



## 2.2 INSTALLATION 1-phase 1x230Vac 50/60Hz

### 2.2.1 CHARGING CURVE OPTIMIZATION

Remove screws from the top and left/right sides in order to open the top cover of the charger.  
Please set the internal adjust terminal block with correct AC voltage setting according to AC voltage detect in the AC input line

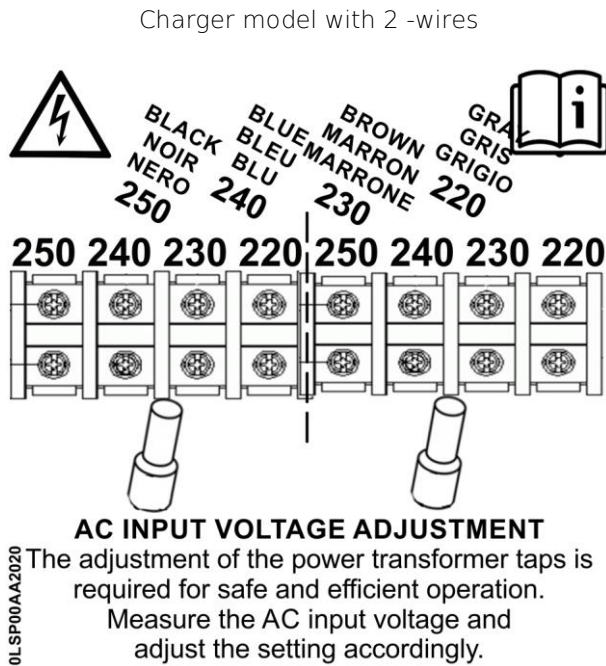
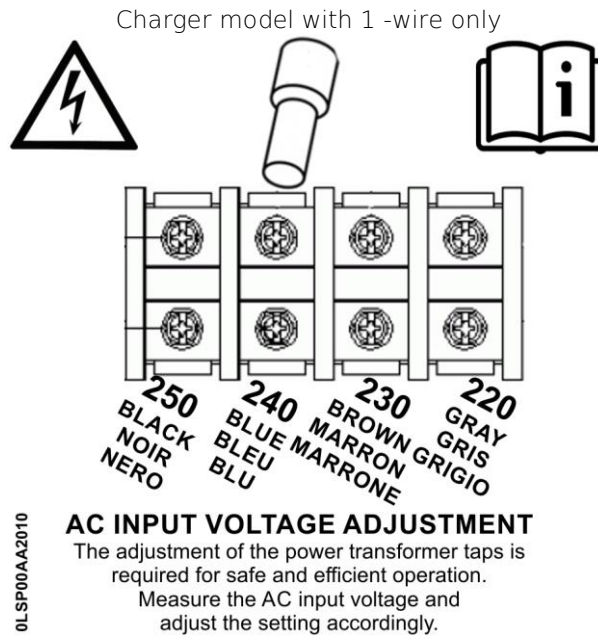

## 2.3 INSTALLATION 1-phase 1x120Vac 60Hz

### 2.3.1 CHARGING CURVE OPTIMIZATION

Please remove screws from the top and left/right sides in order to open the top cover of the charger.  
Please set the internal adjust terminal block with correct AC voltage setting according to AC voltage detect in the AC input line

Charger model with 1 -wire only

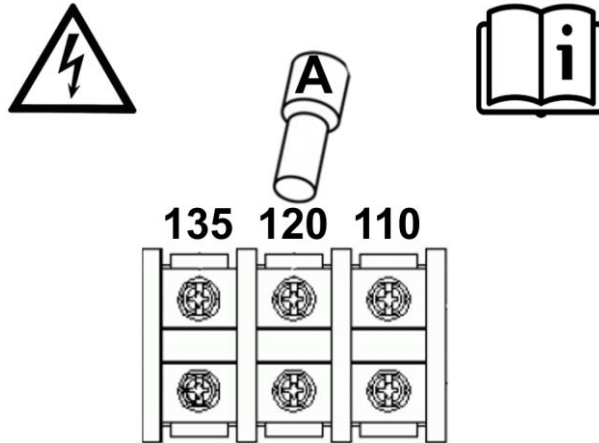

#### **AC INPUT VOLTAGE ADJUSTMENT**

The adjustment of the power transformer taps is required for safe and efficient operation.

Measure the AC input voltage and adjust the setting accordingly.

## 2.4 INSTALLATION 3-phase 3x208/240/480Vac 60Hz

### 2.4.1 NOMINAL VOLTAGE SELECTION

Remove screws from the top and left/right sides in order to open the top cover of the charger.  
 If the charger model is designed for AC Multi Input. Please set the internal terminal board according to the nominal AC Mains provided from the grid



**DANGER:**  
**ELECTRICAL SHOCK CAN BE FATAL**  
 Disconnect power at wall switch.  
**HAUTE TENSION**  
 Assurez-vous que alimentation AC  
 e la batterie sont déconnectées



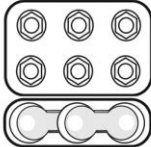

**480 Vac**  
**455-480-510**

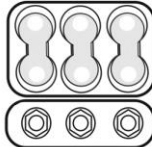

**240 Vac**  
**208-225-240**

**AC INPUT VOLTAGE SETTINGS**  
 The setting of the power transformer taps is  
 required for safe operation.  
 Measure the AC input voltage.

**SELECTION DE LA TENSION NOMINAL**  
 Reglécé bar delta-wye

OLSPO0EC2010C

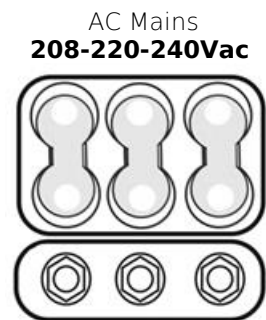

### 2.4.2 CHARGING CURVE OPTIMIZATION

Please set the internal adjust terminal block with correct AC voltage setting according to AC voltage detect in the AC input line



BLACK  
NOIR

RED  
ROUGE

BLUE  
BLEU



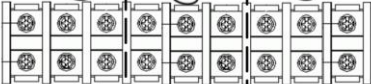

455 480 510 | 455 480 510 | 455 480 510  
 208 225 240 | 208 225 240 | 208 225 240

455 480 505  
 BROWN BLUE BLACK  
 MARRON BLEU NOIR

**AC INPUT VOLTAGE ADJUSTMENT**  
 The adjustment of the power transformer taps is  
 required for safe and efficient operation.  
 Measure the AC input voltage and  
 adjust the setting accordingly.

**OPTIMISATION DE LA COURBE DE CHARGE**

OLSPO0EC2010

## 2.5 INSTALLATION 3-phase 3x480/600Vac 60Hz

### 2.5.1 NOMINAL VOLTAGE SELECTION

Remove screws from the top and left/right sides in order to open the top cover of the charger.  
 If the charger model is designed for AC Multi Input. Please set the internal terminal board according to the nominal AC Mains provided from the grid

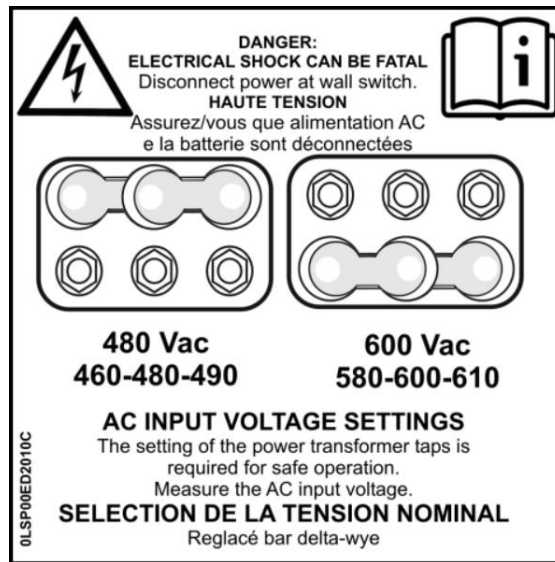

AC Mains  
 460-480-490 Vac

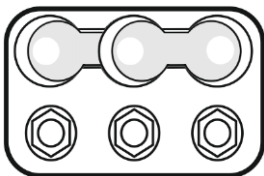

AC Mains  
 580-600-610Vac

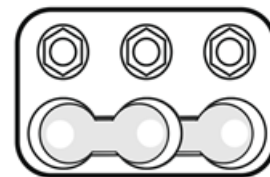

### 2.5.2 CHARGING CURVE OPTIMIZATION

Please set the internal adjust terminal block with correct AC voltage setting according to AC voltage detect in the AC input line

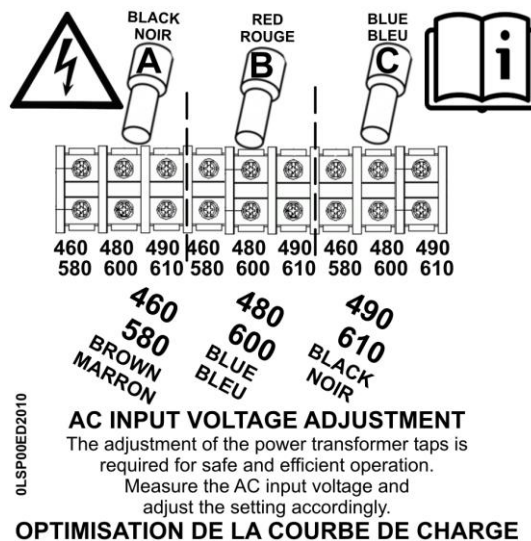

## 2.6 INSTALLATION 1-phase 1x208/240Vac 60Hz

### 2.6.1 CHARGING CURVE OPTIMIZATION

Remove screws from the top and left/right sides in order to open the top cover of the charger. Please set the internal adjust terminal block with correct AC voltage setting according to AC voltage detect in the AC input line

Charger model with 1 -wire only

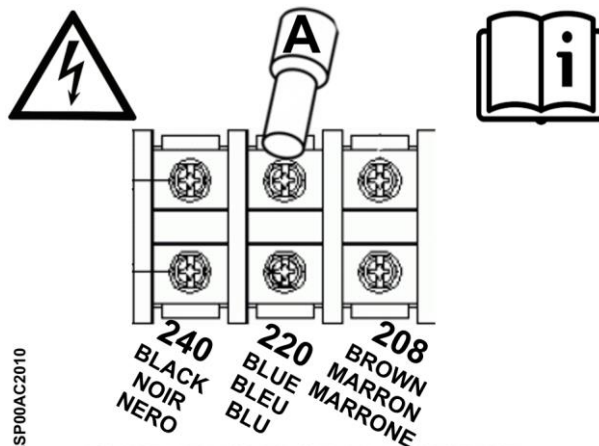

#### AC INPUT VOLTAGE ADJUSTMENT

The adjustment of the power transformer taps is required for safe and efficient operation.

Measure the AC input voltage and adjust the setting accordingly.

#### OPTIMISATION DE LA COURBE DE CHARGE

Charger model with 2 -wires

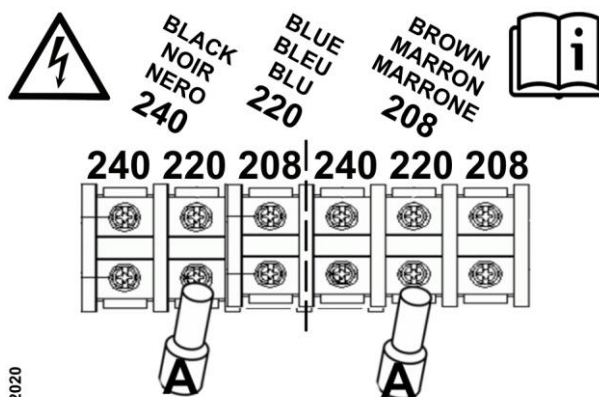

#### AC INPUT VOLTAGE ADJUSTMENT

The adjustment of the power transformer taps is required for safe and efficient operation.

Measure the AC input voltage and adjust the setting accordingly.

#### OPTIMISATION DE LA COURBE DE CHARGE

## 2.7 INSTALLATION 1-phase 1x208/240/480Vac 60Hz

### 2.7.1 CHARGING CURVE OPTIMIZATION

Remove screws from the top and left/right sides in order to open the top cover of the charger.  
Please set the internal adjust terminal block with correct AC voltage setting according to AC voltage detect in the AC input line

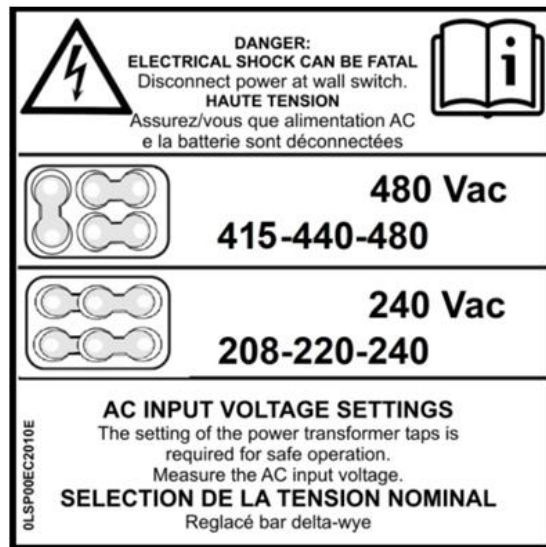

AC Mains  
415-440-480 Vac

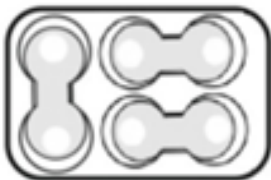

AC Mains  
208-220-240 Vac

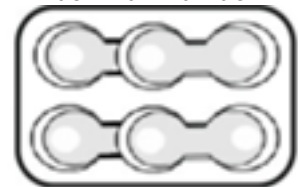

### 2.7.2 CHARGING CURVE OPTIMIZATION

Please set the internal adjust terminal block with correct AC voltage setting according to AC voltage detect in the AC input line

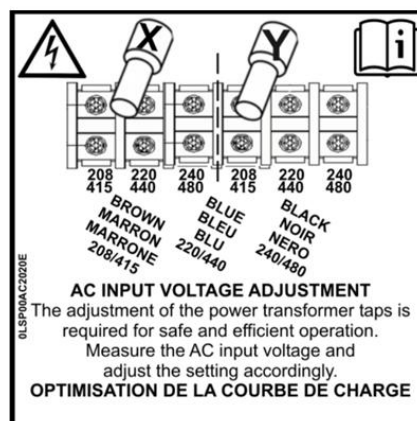



### 3. OPERATION

#### CONTROL BOARD OPERATION

At the connection of the battery, if the battery and the AC input are properly connected, the charger cycle starts automatically.

According to the internal settings, the charge DC current follows the programmed curve.

When the charger output is active and a DC output current is present, LEDs blink.

Colour RED (blink)

During the 1-phase when the battery voltage is low and the output DC current is high

Colour GREEN (blink)

During the Final Phase when the battery voltage is high and the output DC current is low

Colour BLUE (blink)

During the EQ-phase when the battery voltage is very high and the output DC current is very low

During the first phase of charge, the LED RED blinks and the Alarm/Warning LED is off.

In this condition the battery voltage is still low, and the output current of the charger is high.

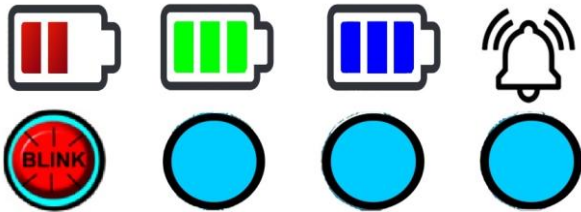

First Phase of Charge

The First Phase will be completed when the battery voltage reaches the Gassing point, after that the charger will begin the Final Phase, where the led GREEN blinks and the Alarm/Warning LED is off.

In this condition the battery voltage is becoming high, and the output current of the charger is low.

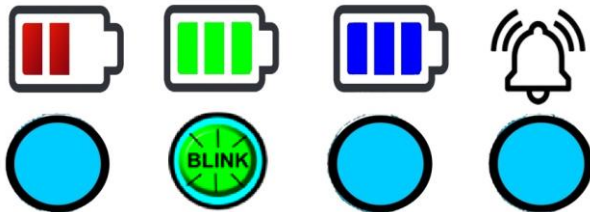

Final Phase of Charge

When the Final Charge is completed the control board stops the charge process. The LED GREEN is solid; the charge process is successfully completed.

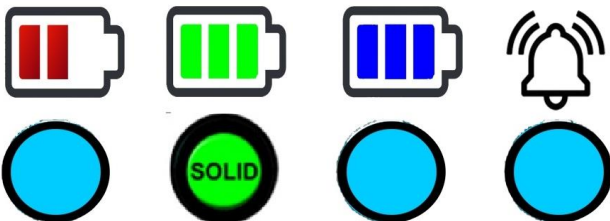

End of the charge process

### EQUALIZATION CYCLE

After the end of the charge process, if the battery remains connected to the charger for many hours, according to the EQ BEGIN TIME setting, the Control Board executes the Equalization cycle.

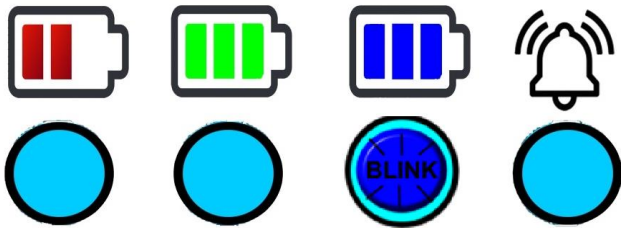

Equalization Cycle

The EQUALIZATION has the function of bringing all the cells to the same state of charge, and to compensate for natural imbalances that occur during the service life of the battery. At the End of the Equalization Cycle the BLUE LED stay solid.

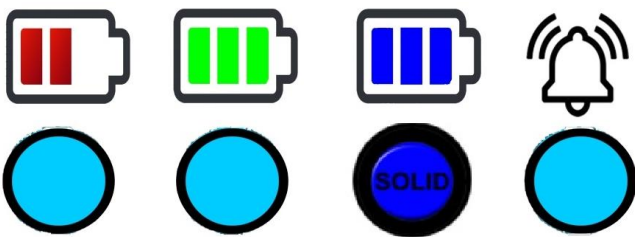

End of the charge process and equalization cycles

### DELAY ON START

It is possible to set a delay on start, in order to allow the battery to cool down before to begin the charging process, or to allow to the charger to operate during an off-peak energy time window. In this case, the charger will wait 1 or more hours before starting the charge process, and the LED configuration will be RED solid during the countdown. The delay can be bypassed by pressing the STOP/RE-START button.

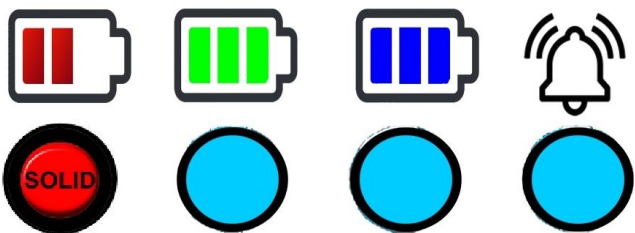

Delay on start

### WARNING SIGNALS

The ALARM/WARNING RED LED will start blinking in these cases: Manual Stop

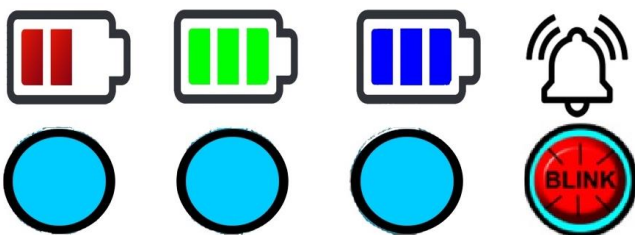

Warning Events



### MANUAL STOP



**DANGER!**

Do not disconnect the battery while it's being charged! RISK OF EXPLOSION!  
Always stop the charger by pushing the STOP button, before disconnecting the battery.  
The ALARM/WARNING LED needs to be in solid light, before to disconnect the battery.

Before to disconnect the battery, please check that leds RED, GREEN or BLUE are not blinking.  
If the charger is providing current, it is recommended to press button "STOP/RE-START" in order to interrupt the charging.  
When the ALARM/WARNING LED blinks and the GREEN LED is solid, it means that the user has properly interrupted the charging or the equalization cycle by pressing the button "STOP/RE-START".  
If the user will press again the button "STOP/RE-START", the charger will restart the cycle from where it left off.

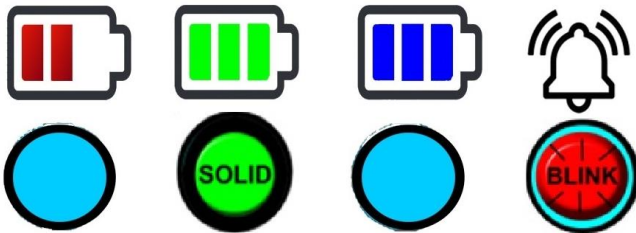

Stop Push-button pressed during the charge cycle or during an equalization cycle

### MANUAL EQUALIZE

During the charging time, it will be possible to request a manual equalize by pressing the EQ button.  
The charger is performing a standard cycle, and at the end it will immediately apply the EQ cycle, instead to wait the defined EQ BEGIN TIME setting.

### HOT DISCONNECTION



**DANGER!**

Do not disconnect the battery while it's being charged! RISK OF EXPLOSION!  
Always stop the charger by pushing the STOP button, before disconnecting the battery.

When the RED, GREEN or BLUE led blinks, the charger is active. Do not disconnect the battery!  
When the RED, GREEN or BLUE led shows a SOLID colour, it is possible to disconnect the battery.

## 4. CONTROL BOARD ALARMS AND TROUBLESHOOTING

If the Alarm/Warning LED is solid means that the charge cycle or an Equalization cycle has been interrupted due to an alarm.

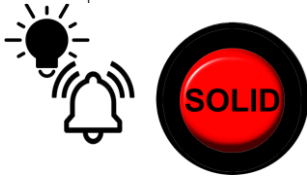

The display shows the cause of the alarm:

- Battery voltage too high
- Gassing Voltage not reached. Exceeded charging Time Out in First Phase
- Battery Temperature too high
- Battery type mismatch, Charging current too low or wrong AC Input setting, Charging current too high

### 4.1 BATTERY VOLTAGE TOO HIGH

The battery voltage reached during the charging cycle or during the equalization cycle is too high, the charge cycle is terminated.

In order to fix this issue, it will be important check the battery status, evaluate voltage of every cell and check intercell connections.

It is recommended to check also the power connections in the DC Plug and DC Socket and in the charger inner parts, in order to identify if the torque of a power connection is insufficient.

The display shows:

CHARGING STOP  
HIGH VOLTAGE

<i>ISSUE</i>	<i>CAUSES</i>	<i>FIX</i>
Alarms appear. During the charging cycle	Battery sulphated	Repair battery.
	Battery nominal voltage is not correct	Check compatibility between battery voltage and charger voltage
	One or more cells are shorted.	Repair battery.

#### 4.2 TIME OUT – GASSING VOLTAGE NOT REACHED

The battery voltage hasn't reached the gassing point within 12 hours of charge. Please check the battery nominal voltage and the charger nominal matching. Please check the AC input mains value and check the internal AC input setting of the charger. it will be important check the battery status, evaluate voltage of every cell and check intercell connections.

The display shows:  
 CHARGING STOP  
 80% NOT REACHED

<i>ISSUE</i>	<i>CAUSES</i>	<i>FIX</i>
Alarms appear. During the charging cycle	Wrong AC input settings.	Adjust AC input settings to lower voltage.
	Battery nominal voltage is not correct	Check compatibility between battery voltage and charger voltage
	Output fuse blown.	Replace output fuse and adjust AC input setting.
	One or more cells are shorted.	Repair battery.

#### 4.3 TEMPERATURE TOO HIGH

CASE A) Temperature sensor installed on the battery

If a temperature sensor has been installed on the battery. During normal operation, if the control board detects an high temperature condition on the battery sensor, the charger will interrupt the charge and apply a cooling pause, at the end of the pause, the charger will restart from the point where it stopped.

CASE B) Temperature sensor installed on the charger

If a temperature sensor has been installed inside or outside the charger. During normal operation, if the control board detects an high temperature condition on the NTC100 sensor, the charger will interrupt the charge and apply a cooling pause, at the end of the pause, the charger will restart from the point where it stopped.

The display shows:  
 CHARGING STOP  
 HIGH TEMPERATURE

<i>ISSUE</i>	<i>CAUSES</i>	<i>FIX</i>
Alarms appear. During the charging cycle	AC input mains is too high or it is too low	Please check AC mains and the charger AC input setting
	Charger ventilation slots obstructed or bad location	Please check charger installation and location, in order to allow ventilation. Remove objects which may obstruct slots.
	Battery high temperature	Please check battery installation and battery location, in order to allow ventilation. Please evaluate to reduce the charger current

### 4.4 BATTERY TYPE MISMATCH

CASE A) BATTERY NOMINAL VOLTAGE LOW

The battery voltage is too low: the charge cycle doesn't begin.

CASE B) BATTERY NOMINAL VOLTAGE HIGH

The battery voltage is too high: the charge cycle doesn't begin.

CASE C) BATTERY NOMINAL VOLTAGE ERROR

The charge current is too high: the charger shuts down immediately.

The display shows:

CHARGING STOP

NOMINAL VOLTAGE, CURRENT TOO HIGH, HIGH VOLTAGE, LOW VOLTAGE, CHECK OUTPUT FUSE

ISSUE	CAUSES	FIX
Alarms appear. The charger is not starting	Battery not connected properly.	Check battery connectors/harness.
	Output cables reversed.	Check charger, connectors and battery polarities. Output fuse is probably blown.
	Battery nominal voltage is not correct	Check compatibility between battery voltage and charger voltage

### 4.5 NO ALARM – LEDs NO FLASHING

After the connection of the DC plug, the charger is not starting to charge. Display and Leds are not providing any light information. The charger seems totally OFF.

ISSUE	CAUSES	FIX
The charger is not starting, Leds are not flashing	Battery not connected properly.	Check battery connectors/harness.
	Output cables reversed.	Check charger, connectors and battery polarities. Output fuse is probably blown.
	Internal Thermal protector is enabled	Please check charger installation and location, in order to allow ventilation. Remove objects which may obstruct slots. Manually Reset the Thermal Protector

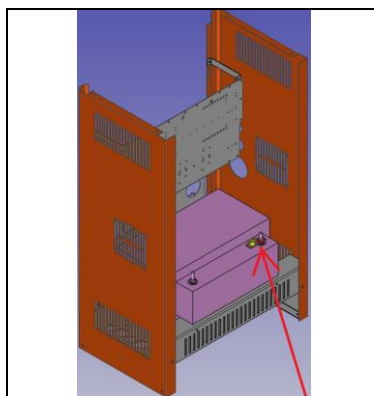

Push the button, in order to apply a Manual Reset to the Internal Thermal protector