

GECI™ MOD 6, 8 and X USER'S MANUAL

Before connecting the battery charger to the mains and to the battery, READ THE FOLLOWING INSTRUCTIONS CAREFULLY.

GENERAL WARNINGS

- 1) Before each use of the battery charger the instructions set out below must be carefully read and abided by.
- 2) The failure to follow these instructions and /or errors in installing or using the battery charger could lead to endangering the operator and /or damaging the device, voiding the manufacturer's guarantee.
- 3) The battery charger cannot be used as a component in systems which provide life support and/or medical devices.
- 4) The battery charger must not be used by persons with reduced physical, sensory and mental capabilities or with lack of experience and/or knowledge, unless they are properly supervised and instructed by a person responsible for their safety.
- 5) The rating label must be visible after installation.

CHILDREN

- 6) This appliance can be used by children aged from 8 years and above and persons with reduced physical, sensory or mental capabilities or lack of experience and knowledge if they have been given supervision or instruction concerning use of the appliance in a safe way and understand the hazards involved. Children being supervised not to play with the appliance. Cleaning and user maintenance shall not be made by children without supervision.



>>>NOTE<<<

The specifications set out in this manual are subject to change without any notice. This publication replaces any previously supplied information.

WHERE TO INSTALL

- 7) Never place the battery charger in the immediate vicinity of the battery in order to prevent gases produced and/or emitted by the actual battery during charging corroding and/or damaging the battery charger. Place the battery charger as far away from the battery as the length of cables permits.
- 8) Do not install the battery charger in a closed space or in such a way as to somehow prevent ventilation. For units equipped with fans, at least 30 mm clearance must be left around the vents. In order to facilitate the heat exchange of the battery charger it must be positioned vertically, exploiting the fixture holes (where provided).
- 9) Do not use the battery charger outdoors.
- 10) Do not expose the battery charger to rain, water splashes or steam.
- 11) Do not install the battery charger in caravans and / or similar vehicles.
- 12) Do not install the battery charger near any heat sources or in areas with high concentrations of dust.
- 13) Do not install the battery charger near any potential sources of flammable material, for example methane gas pipes or fuel depots (petrol, kerosene, ...).
- 14) Do not place and/or fit the battery charger onto surfaces manufactured out of combustible materials, like wooden shelves or walls.

BATTERIES

- 15) Follow the specific safety instructions provided by the battery manufacturer carefully, for example, whether or not to remove cell caps during charging and the recommended charge rates.
- 16) Working in the vicinity of a lead-acid battery is dangerous, as batteries generate explosives gases during charging. Therefore smoking and/or generating open flames and/or sparks must be avoided.
- 17) Never charge a frozen battery.
- 18) Batteries must be charged in specific, well-ventilated areas.
- 19) In order to reduce risk of injury only charge Lead-Acid, GEL or AGM type, Lithium Polymer or Lithium Ion batteries. Do not charge other types of rechargeable or non-rechargeable batteries as they could explode causing damage and/or injury.

FURTHER SPECIFICATIONS FOR LITHIUM BATTERIES

- 20) In order to charge Lithium Polymer and Lithium Ion batteries, a BMS (Battery Management System) must always be used, comprising an active and passive safety system, in compliance with safety regulations in force.
- 21) The possibility of the BMS acting directly on the battery charger operation during cell balancing phases rules out, for any reason whatsoever, that the battery charger is held directly responsible should damage caused to the battery, or even a fire or an explosion, be due to an error in the BMS software.
- 22) The faculty offered by the materials produced by S.P.E. ELETTRONICA INDUSTRIALE to select different levels of voltage for charging, is entrusted to the control and supervision of the end user and S.P.E. ELETTRONICA INDUSTRIALE is not liable for any consequences resulting from the selection of the incorrect level of voltage. If in doubt, the user should ask a qualified professional for clarification.
- 23) The battery charger tolerance thresholds, as far as levels of over-voltage and overcharging are concerned, are used only for the safeguarding of the systems of the same and have no safety functions for the battery itself, the safety of which depends solely on the BMS, even when the battery charger is connected to the battery, whether the latter is being charged or not.
- 24) Should the client want to use the battery charger on a specific on-board system and in general in any cases of special usage, it is the client's responsibility to inform S.P.E. ELETTRONICA INDUSTRIALE, so that the latter can draw up any necessary recommendations. In this case, the client must provide S.P.E. ELETTRONICA INDUSTRIALE with all designs, diagrams and descriptive material necessary. S.P.E. ELETTRONICA INDUSTRIALE cannot be held responsible for any damage resulting from the use of the battery charger after opening it and/or modifying it and/or inserting it into other systems.
- 25) Under no circumstances can S.P.E. ELETTRONICA INDUSTRIALE be held responsible for the malfunctioning of the batteries or the incineration/explosion of these, in so much as the safety of the battery is the task of the BMS and not of the battery charger.

CHECKING CABLES, GRID, EARTHING

- 26) Do not transport the battery charger by pulling on the cables as they could be damaged. Use the handles on the battery charger, if provided.
- 27) Before using the battery charger, check that the sleeving on the mains cable and battery cables is in good condition. Should one of the cables be damaged, have it replaced by a S.P.E. ELETTRONICA INDUSTRIALE qualified technician.
- 28) Check that the input voltage of the battery charger given on the data plate is in line with the voltage available.
- 29) Check the compatibility of the mains plug supplied with the battery charger: the use of adaptors is not recommended (in Canada it is against the law). If the input plug does not fit the power outlet, contact SPE ELETTRONICA INDUSTRIALE for the proper cord set terminating in an attachment plug of the proper configuration for the power outlet. If the supply cord is damaged, it must be replaced by the manufacturer, its service agent or similarly qualified persons in order to avoid a hazard.
- 30) The battery charger must be plugged into a socket fitted with an earth wire. Should the socket not be equipped with an earth connection, do not use the device before having a suitable socket installed by a qualified technician.
- 31) The power socket to which the battery charger is to be connected must be protected by an electrical device by law (fuse and/or automatic cut-out), capable of absorbing an electrical current equaling the absorption of current stated on the matriculation number of the battery charger, increased by 10%.
- 32) Do not open the battery charger as there are no parts which can be serviced and/or replaced by the user. Only specialized personnel, authorized by S.P.E. ELETTRONICA INDUSTRIALE may carry out servicing which involves opening the actual device. Electrical/electronic components inside may cause electric shocks even if the device is not plugged in.

CHECKING BATTERY CHARGER OPERATION AND CURVE

- 33) Before charging, make sure that the battery charger is in line with the voltage of the battery, that the charging current suits the capacity of the battery and that the selected charging curve (for lead-acid batteries, or for airtight GEL or AGM type batteries, Lithium Polymer or Lithium Ion batteries) is correct for the type of battery to be charged. In case of recharging floor treatment machine, ensure the machine is switched off and not used.
- 34) We recommend fitting a fuse between battery charger and battery. The fuse must be installed along the connection to the positive terminal of the battery. The rating of the fuse must be proportionate to the nominal output current of the battery charger, the diameter of cable used and the environment in which it is to be installed.
- 35) We recommend unplugging it from the mains supply before connecting and disconnecting batteries.
- 36) During normal operation of the battery charger, the external surface may become hot and may remain so for a certain period of time after it has been switched off.
- 37) The battery charger needs no special maintenance, only regular cleaning procedures, to be carried out according to the type of working environment. Cleaning procedures should only be carried out on the external surface of the battery charger. Before starting any cleaning procedures, the mains supply cable and battery cables must be unplugged. Do NOT use water and/or detergents in general and/or pressure washers of any kind when carrying out cleaning.

NOT IN USE

- 38) If safe operation of the battery charger can no longer be ensured, stop the device and ensure that it cannot be put back into operation.

Battery type LEAD-ACID, GEL, AGM, LITHIUM

Number of cells = 6 - 12 - 18 - 24 - 36 - 40 - 48

>>>CAUTION!<<<

Risk of Fire. Charge LEAD-Acid, Gel, AGM and Lithium batteries. For Lithium: Use only battery packs that include BMS and all necessary protection for the battery pack integral to the pack.

>>>DANGER!<<<

Risk of electric shock. Do not touch uninsulated portion of output connector or uninsulated battery terminal.

>>>CAUTION!<<<

Risk of Fire. Use only on circuits provided with _____ amperes branch circuit protection in accordance with the National Electrical Code, NFPA 70."

GECI™ MOD 6, 8 and X IDENTIFICATION LABEL

- A CUSTOMER PART NUMBER
- B PART NUMBER
- C MODEL
- D INPUT VOLTAGE AND MAINS ABSORPTION
- E OUTPUT VOLTAGE AND CURRENT
- F SETTING
- G BATTERY CHARGER MANUFACTURE DATE
- H BATTERY CHARGER SERIAL NUMBER
- I ATTENTION
- L PRODUCT CERTIFICATIONS STAMP
- M BATTERY TYPE

S.P.E. ELETTRONICA INDUSTRIALE ATTENTION: I	CP/N:	A	L CE
	P/N:	B	
	Model:	C	
	Input:	D	
	Output:	E	
	Setting:	F	
	Date:	G	
	S/N:	H	

S.P.E. ELETTRONICA INDUSTRIALE CREVALCORE (BO) ITALY Via di Mezzo Ponente, 383/B WARNING	CE L 	CP/N:	A
		P/N:	B
		Model:	C
		Input:	D
		Output:	E
		Battery Type:	M
		Setting:	F
		Date:	G
		S/N:	H
???????			

Storage temperature: from -20°C to +50°C
 Relative humidity: 0 - 80% up to 50°C
 Operating temperature: from 0°C to 40°C

Battery Chargers nnnVac three phases mains (also available for Lithium Battery Packs)

- M Model
- BV Battery Voltage
- CC Charging Current
- MIC Max Input Current
- BC Battery Capacity
- AC MCD AC Mains Cabel Description

Battery Chargers 380 - 415Vac three phases mains (also available for Lithium Battery Packs)

M	BV [V]	CC [A]	MIC [A]	BC [Ah C5]	AC MCD
GREEN6 24-50	24	50	3	350 – 420	4 x 2.5mm ² / 4 x 12AWG (O.D. Ø12,7mm) 450 / 750V
GREEN6 24-60	24	60	4	420 – 510	
GREEN6 24-70	24	70	4.5	480 – 590	
GREEN6 24-80	24	80	5	550 – 680	
GREEN6 24-100	24	100	6	690 – 850	
GREEN6 24-120	24	120	8	830 – 1020	4 x 4mm ² / 4 x 10AWG (O.D. Ø14,6mm) 450 / 750V
GREEN6 24-150	24	150	10	1040 – 1270	

GREEN8 24-160	24	160	10	1110 – 1350	4 x 6mm ² / 4 x 10AWG (O.D. Ø16,4mm) 450 / 750V
GREEN8 24-180	24	180	12	1250 – 1520	
GREEN8 24-200	24	200	13	1380 – 1690	
GREENX 24-250	24	250	16	1730 – 2120	
GREENX 24-300	24	300	19	2080 – 2540	
GREEN6 36-80	36	80	8	550 – 680	4 x 2.5mm ² / 4 x 12AWG (O.D. Ø12,7mm) 450 / 750V
GREEN6 36-100	36	100	10	690 – 850	
GREEN6 36-120	36	120	12	830 – 1020	4 x 4mm ² / 4 x 10AWG (O.D. Ø14,6mm) 450 / 750V
GREEN6 36-150	36	150	14	1040 – 1270	
GREEN8 36-180	36	180	17	1250 – 1520	4 x 6mm ² / 4 x 10AWG (O.D. Ø16,4mm) 450 / 750V
GREEN8 36-200	36	200	19	1380 – 1690	
GREENX 36-250	36	250	20	1730 – 2120	
GREENX 36-300	36	300	21	2080 – 2540	
GREEN6 48-25	48	25	3	170 – 210	4 x 2.5mm ² / 4 x 12AWG (O.D. Ø12,7mm) 450 / 750V
GREEN6 48-30	48	30	2.8	210 – 255	
GREEN6 48-40	48	40	5	280 – 340	
GREEN6 48-50	48	50	6	350 – 420	
GREEN6 48-60	48	60	8	420 – 510	
GREEN6 48-70	48	70	9	480 – 590	
GREEN6 48-80	48	80	10	550 – 680	
GREEN6 48-90	48	90	12	620 – 760	
GREEN6 48-100	48	100	13	690 – 850	
GREEN6 48-120	48	120	15	830 – 1020	4 x 4mm ² / 4 x 10AWG (O.D. Ø14,6mm) 450 / 750V
GREEN6 48-130	48	130	17	900 – 1100	
GREEN6 48 150	48	150	19	1040 – 1270	
GREEN8 48-160	48	160	21	1110 – 1350	4 x 6mm ² / 4 x 10AWG (O.D. Ø16,4mm) 450 / 750V
GREEN8 48-180	48	180	23	1250 – 1520	
GREEN8 48-200	48	200	26	1380 – 1690	
GREENX 48-250	48	250	32	1730 – 2120	
GREENX 48-300	48	300	38	2070 – 2540	
GREEN6 72-30	72	30	6	210 – 255	4 x 2.5mm ² / 4 x 12AWG (O.D. Ø12,7mm) 450 / 750V
GREEN6 72-40	72	40	7.5	275 – 340	
GREEN6 72-50	72	50	10	350 – 420	
GREEN6 72-60	72	60	12	420 – 510	
GREEN6 72-80	72	80	15	550 – 680	4 x 4mm ² / 4 x 10AWG (O.D. Ø14,6mm) 450 / 750V
GREEN6 72-100	72	100	19	690 – 850	
GREEN8 72-130	72	130	25	900 – 1100	4 x 6mm ² / 4 x 10AWG (O.D. Ø16,4mm) 450 / 750V

GREEN6 80-30	80	30	6.5	210 – 255	4 x 2.5mm ² / 4 x 12AWG (O.D. Ø12,7mm) 450 / 750V
GREEN6 80-40	80	40	8.5	275 – 340	
GREEN6 80-50	80	50	11	350 – 420	
GREEN6 80-60	80	60	13	420 – 510	
GREEN6 80-80	80	80	17	550 – 680	4 x 4mm ² / 4 x 10AWG (O.D. Ø14,6mm) 450 / 750V
GREEN6 80-100	80	100	21	690 – 850	
GREEN8 80-110	80	110	23	760 – 930	4 x 6mm ² / 4 x 10AWG (O.D. Ø16,4mm) 450 / 750V
GREEN8 80-120	80	120	26	830 – 1020	
GREEN8 80-130	80	130	28	900 – 1100	
GREENX 80-150	80	150	32	1040 – 1270	
GREENX 80-160	80	160	34	1110 – 1350	
GREENX 80-200	80	200	43	1380 – 1690	
GREEN6 96-20	96	20	5	140 – 170	4 x 2.5mm ² / 4 x 12AWG (O.D. Ø12,7mm) 450 / 750V
GREEN6 96-25	96	25	6	170 – 210	
GREEN6 96-30	96	30	8	210 – 255	
GREEN6 96-40	96	40	10	280 – 340	
GREEN6 96-50	96	50	13	350 – 420	
GREEN6 96-60	96	60	15	420 – 510	4 x 4mm ² / 4 x 10AWG
GREEN6 96-65	96	65	17	450 – 550	(O.D. Ø14,6mm) 450 / 750V
GREEN6 96-60	96	70	18	480 – 590	
GREEN6 96-75	96	75	19	520 – 630	
GREEN8 96-80	96	80	21	550 – 680	4 x 6mm ² / 4 x 10AWG (O.D. Ø16,4mm) 450 / 750V
GREEN8 96-100	96	100	26	690 – 850	
GREENX 96-125	96	125	32	870 – 1060	
GREENX 96-150	96	150	38	1040 – 1270	

**Battery Chargers 200Vac three phases mains
(also available for Lithium Battery Packs)**

M	BV [V]	CC [A]	MIC [A]	BC [Ah C5]	AC MCD
GREEN6 36-100	36	100	20	690 – 850	4 x 4mm ² / 4 x 10AWG (O.D. Ø14,6mm) 450 / 750V
GREEN6 48-100	48	100	26	690 – 850	4 x 6mm ² / 4 x 10AWG (O.D. Ø16,4mm) 450 / 750V
GREEN6 48-150	48	150	38	1040 – 1270	
GREEN8 48-200	48	200	43	1380 – 1690	
GREEN8 80-30	80	30	13	210 – 255	4 x 2.5mm ² / 4 x 12AWG (O.D. Ø12,7mm) 450 / 750V
GREEN8 80-130	80	130	46.5	900 – 1100	4 x 6mm ² / 4 x 10AWG (O.D. Ø16,4mm) 450 / 750V

**Battery Chargers 220Vac three phases mains
(also available for Lithium Battery Packs)**

M	BV [V]	CC [A]	MIC [A]	BC [Ah C5]	AC MCD
GREEN6 24-50	24	50	5	350 – 420	4 x 4mm ² / 4 x 10AWG (O.D. Ø14,6mm) 450 / 750V
GREEN6 24-80	24	80	8	550 – 680	
GREEN6 24-100	24	100	10.5	690 – 850	
GREEN6 24-120	24	120	12	830 – 1020	4 x 6mm ² / 4 x 10AWG (O.D. Ø16,4mm) 450 / 750V
GREEN6 24-150	24	150	15	1040 – 1270	
GREEN6 36-100	36	100	15.5	690 – 850	4 x 4mm ² / 4 x 10AWG (O.D. Ø14,6mm) 450 / 750V
GREEN6 36-120	36	120	18	830 – 1020	4 x 6mm ² / 4 x 10AWG (O.D. Ø16,4mm) 450 / 750V
GREEN6 36-150	36	150	23	1041 – 1270	
GREEN8 36-160	36	160	24	1110 – 1350	
GREEN8 36-200	36	200	30.5	1380 – 1690	
GREEN6 48-100	48	100	21	690 – 850	4 x 4mm ² / 4 x 10AWG (O.D. Ø14,6mm) 450 / 750V
GREEN6 48-120	48	120	24	830 – 1020	4 x 6mm ² / 4 x 10AWG (O.D. Ø16,4mm) 450 / 750V
GREEN6 48-130	48	130	26.5	900 – 1100	
GREEN6 36-150	48	150	31	1040 – 1270	
GREEN8 48-200	48	200	41	1380 – 1690	
GREEN6 72-100	72	100	31	690 – 850	
GREEN6 80-80	80	80	27	550 – 680	4 x 6mm ² / 4 x 10AWG (O.D. Ø16,4mm) 450 / 750V
GREEN6 80-100	80	100	34	690 – 850	
GREEN8 80-120	80	120	41	830 – 1020	
GREEN8 80-130	80	130	44	900 – 1100	

**Battery Chargers 440Vac three phases mains
(also available for Lithium Battery Packs)**

M	BV [V]	CC [A]	MIC [A]	BC [Ah C5]	AC MCD
GREEN6 24-80	24	80	5	550 – 680	4 x 2.5mm ² / 4 x 12AWG (O.D. Ø12,7mm) 450 / 750V
GREEN6 24-100	24	100	6	690 – 850	
GREEN6 24-120	24	120	7	830 – 1020	4 x 4mm ² / 4 x 10AWG (O.D. Ø14,6mm) 450 / 750V
GREEN8 24-200	24	200	12	1380 – 1690	4 x 6mm ² / 4 x 10AWG (O.D. Ø16,4mm) 450 / 750V
GREEN8 36-200	36	200	17	1380 – 1690	
GREEN6 48-150	48	150	17	1040 – 1270	4 x 4mm ² / 4 x 10AWG (O.D. Ø14,6mm) 450 / 750V
GREEN8 48-200	48	200	23	1380 – 1690	4 x 6mm ² / 4 x 10AWG (O.D. Ø16,4mm) 450 / 750V

**Battery Chargers 208Vac three phases mains
(also available for Lithium Battery Packs)**

M	BV [V]	CC [A]	MIC [A]	BC [Ah C5]	AC MCD
GREEN6 24-100	24	100	10.6	690 – 850	4 x 2.5mm ² / 4 x 12AWG (O.D. Ø12,7mm) 450 / 750V
GREEN6 24-120	24	120	12.8	830 – 1020	4 x 4mm ² / 4 x 10AWG (O.D. Ø14,6mm) 450 / 750V
GREEN6 36-80	36	80	15	550 – 680	4 x 2.5mm ² / 4 x 12AWG (O.D. Ø12,7mm) 450 / 750V
GREEN6 36-150	36	150	23.9	1040 – 1270	4 x 4mm ² / 4 x 10AWG (O.D. Ø14,6mm) 450 / 750V
GREEN6 48-100	48	100	21.3	690 – 850	4 x 2.5mm ² / 4 x 12AWG (O.D. Ø12,7mm) 450 / 750V
GREEN6 48-150	48	150	31.9	1040 – 1270	4 x 4mm ² / 4 x 10AWG (O.D. Ø14,6mm) 450 / 750V
GREEN8 48-200	48	200	42.6	1380 – 1690	4 x 6mm ² / 4 x 10AWG (O.D. Ø16,4mm) 450 / 750V

**Battery Chargers 480Vac three phases mains
(also available for Lithium Battery Packs)**

M	BV [V]	CC [A]	MIC [A]	BC [Ah C5]	AC MCD
GREEN6 24-50	24	50	2.3	350 – 420	4 x 2.5mm ² / 4 x 12AWG (O.D. Ø12,7mm) 450 / 750V
GREEN6 24-60	24	60	2.8	420 – 510	
GREEN6 24-70	24	70	3.2	480 – 590	
GREEN6 24-80	24	80	3.7	550 – 680	
GREEN6 24-90	24	90	4.1	620 – 760	
GREEN6 24-100	24	100	4.6	690 – 850	
GREEN6 24-110	24	110	5.1	760 – 930	4 x 4mm ² / 4 x 10AWG (O.D. Ø14,6mm) 450 / 750V
GREEN6 24-120	24	120	5.5	830 – 1020	
GREEN6 24-130	24	130	6.0	900 – 1100	
GREEN6 24-140	24	140	6.5	970 – 1180	
GREEN6 24-150	24	150	6.9	1040 – 1270	
GREEN8 24-160	24	160	7.4	1110 – 1350	
GREEN8 24-170	24	170	7.8	1180 – 1440	4 x 4mm ² / 4 x 10AWG (O.D. Ø16,4mm) 450 / 750V
GREEN8 24-180	24	180	8.3	1250 – 1520	
GREEN8 24-190	24	190	8.8	1320 – 1610	
GREEN8 24-200	24	200	9.2	1380 – 1690	
GREENX 24-210	24	210	9.7	1450 – 1780	
GREENX 24-220	24	220	10.1	1520 – 1860	
GREENX 24-230	24	230	10.6	1590 – 1950	4 x 6mm ² / 4 x 10AWG (O.D. Ø16,4mm) 450 / 750V
GREENX 24-240	24	240	11.1	1660 – 2030	
GREENX 24-250	24	250	11.5	1730 – 2120	
GREENX 24-260	24	260	12.0	1800 – 2200	
GREENX 24-270	24	270	12.4	1870 – 2280	
GREENX 24-280	24	280	12.9	1940 – 2370	
GREENX 24-290	24	290	13.4	2010 – 2450	
GREENX 24-300	24	300	13.8	2080 – 2540	
GREEN6 36-50	36	50	3.5	350 – 420	4 x 2.5mm ² / 4 x 12AWG (O.D. Ø12,7mm) 450 / 750V
GREEN6 36-60	36	60	4.1	420 – 510	
GREEN6 36-70	36	70	4.8	480 – 590	
GREEN6 36-80	36	80	5.5	550 – 680	
GREEN6 36-90	36	90	6.2	620 – 760	
GREEN6 36-100	36	100	6.9	690 – 850	

GREEN6 36-110	36	110	7.6	760 – 930	4 x 4mm ² / 4 x 10AWG (O.D. Ø14,6mm) 450 / 750V
GREEN6 36-120	36	120	8.3	830 – 1020	
GREEN6 36-130	36	130	9.0	900 – 1100	
GREEN6 36-140	36	140	9.7	970 – 1180	
GREEN6 36-150	36	150	10.4	1040 – 1270	
GREEN8 36-160	36	160	11.1	1110 – 1350	4 x 6mm ² / 4 x 10AWG (O.D. Ø16,4mm) 450 / 750V
GREEN8 36-170	36	170	11.8	1180 – 1440	
GREEN8 36-180	36	180	12.4	1250 – 1520	
GREEN8 36-190	36	190	13.1	1320 – 1610	
GREEN8 36-200	36	200	13.8	1380 – 1690	
GREENX 36-210	36	210	14.5	1450 – 1780	
GREENX 36-220	36	220	15.2	1520 – 1860	
GREENX 36-230	36	230	15.9	1590 – 1950	
GREENX 36-240	36	240	16.6	1660 – 2030	
GREENX 36-250	36	250	17.3	1730 – 2120	
GREENX 36-260	36	260	18.0	1800 – 2200	4 x 6mm ² / 4 x 10AWG (O.D. Ø16,4mm) 450 / 750V
GREENX 36-270	36	270	18.7	1870 – 2280	
GREENX 36-280	36	280	19.4	1940 – 2370	
GREENX 36-290	36	290	20.1	2010 – 2450	
GREENX 36-300	36	300	20.7	2080 – 2540	
GREEN6 48-50	48	50	4.6	350 – 420	4 x 2.5mm ² / 4 x 12AWG (O.D. Ø12,7mm) 450 / 750V
GREEN6 48-60	48	60	5.5	420 – 510	
GREEN6 48-70	48	70	6.5	480 – 590	
GREEN6 48-80	48	80	7.4	550 – 680	
GREEN6 48-90	48	90	8.3	620 – 760	
GREEN6 48-100	48	100	9.2	690 – 850	
GREEN6 48-110	48	110	10.1	760 – 930	4 x 4mm ² / 4 x 10AWG (O.D. Ø14,6mm) 450 / 750V
GREEN6 48-120	48	120	11.1	830 – 1020	
GREEN6 48-130	48	130	12.0	900 – 1100	
GREEN6 48-140	48	140	12.9	970 – 1180	
GREEN6 48 150	48	150	13.8	1040 – 1270	
GREEN8 48-160	48	160	14.8	1110 – 1350	4 x 4mm ² / 4 x 10AWG (O.D. Ø16,4mm) 450 / 750V
GREEN8 48-170	48	170	15.7	1180 – 1440	
GREEN8 48-180	48	180	16.6	1250 – 1520	
GREEN8 48-190	48	190	17.5	1320 – 1610	
GREEN8 48-200	48	200	18.4	1380 – 1690	

GREENX 48-210	48	210	19.4	1450 – 1780	4 x 6mm ² / 4 x 10AWG (O.D. Ø16,4mm) 450 / 750V
GREENX 48-220	48	220	20.3	1520 – 1860	
GREENX 48-230	48	230	21.2	1590 – 1950	
GREENX 48-240	48	240	22.1	1660 – 2030	
GREENX 48-250	48	250	23.1	1730 – 2120	
GREENX 48-260	48	260	24.0	1800 – 2200	
GREENX 48-270	48	270	24.9	1870 – 2280	
GREENX 48-280	48	280	25.8	1940 – 2370	
GREENX 48-290	48	290	26.7	2010 – 2450	
GREENX 48-300	48	300	27.7	2080 – 2540	

MAINS CONNECTION

The battery charger must be connected to a socket proportionate in power to the charger. Check it on the rating label positioned on the side of the charger:

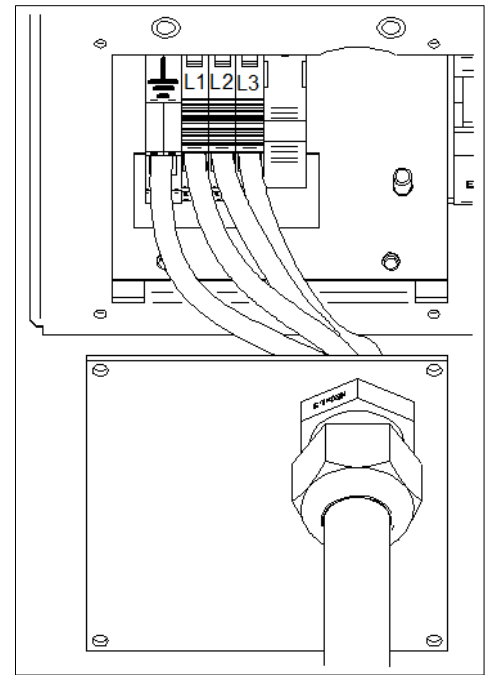

Standard mains connection

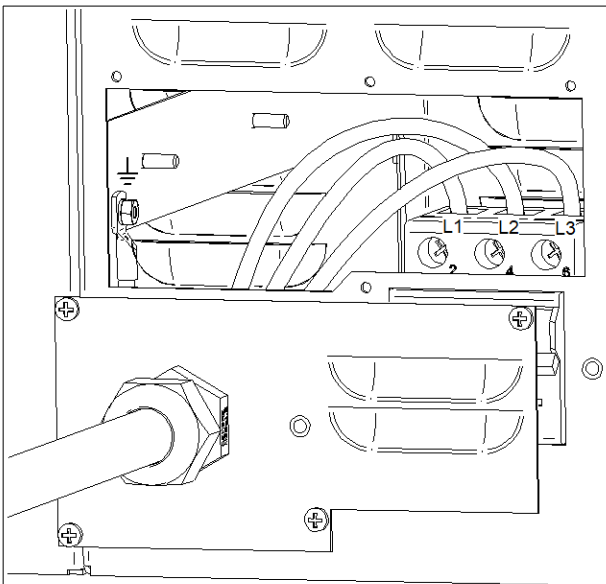

Alternative mains connection

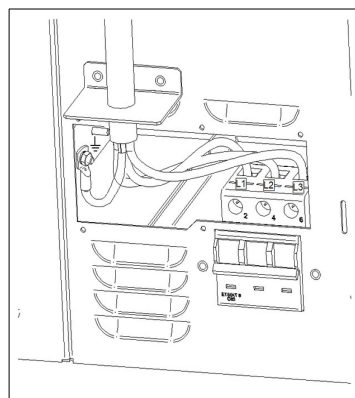

Cable conduit wiring connection

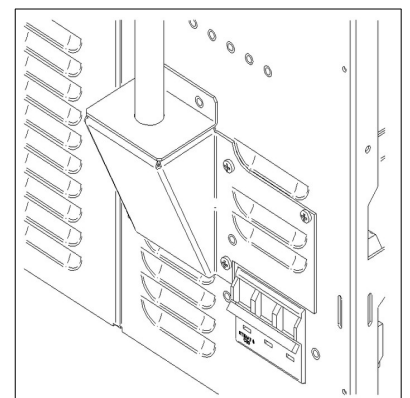

BATTERY CONNECTION

The battery charger is already provided of battery connector. In any case, we recommend using appropriate compliant bipolar connectors which do not allow polarity reverse. Ensure the battery leads are correctly crimped to the connector's contacts and themselves are well inserted into the battery connector.

Only specialized personnel should carry out this procedure.

VISUAL SIGNALS

This paragraph describes the displays of the 4 status LEDs during the different operational phases of the battery charger.

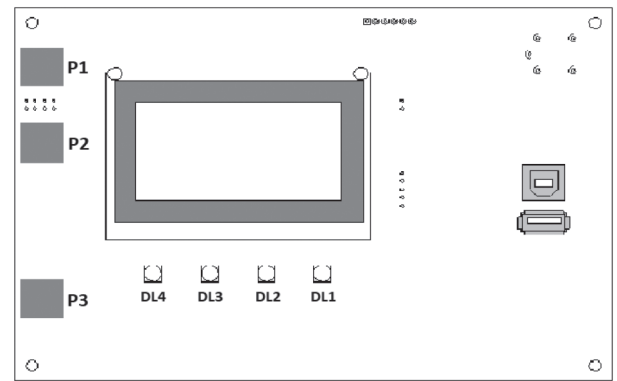

REF	DESCRIPTION	DL4 LED (green)	DL3 LED (yellow)	DL2 LED (green)	DL1 LED (red)	DISPLAY
S1	Only battery power supply	OFF	OFF	OFF	OFF	OFF
S2	Only mains power supply	OFF	OFF	OFF	OFF	ON
S3	Both mains and battery power supply	ON	OFF	OFF	OFF	ON
S4	Perform Autostart	BL	BL	BL	BL	ON
F1	Phase 1 – Initial charge CI	BL	OFF	OFF	OFF	ON
F2-F7	Phase 2 – Phase 7	BL	ON	OFF	OFF	ON
F8	Equalisation period	ON	ON	ON	OFF	ON
EQU ON	Equalisation charge ON (in progress)	BL	BL	ON	OFF	ON
					OFF	ON
EQU OFF	Equalisation charge OFF (paused)	ON	ON	ON	OFF	ON
M	Maintenance	BL	BL	ON	OFF	ON
END	Charge Finished	ON	ON	ON	OFF	ON

Where:

OFF = the led is off

ON = the led is constant

BL = the led is blinking (Blink, T=1 second)

-- = the led can be in any condition

LCD DISPLAY

During charging, the battery charger offers 3 monitor menus, which you can move between by pressing the P2 button, and whose detailed meaning was previously illustrated.

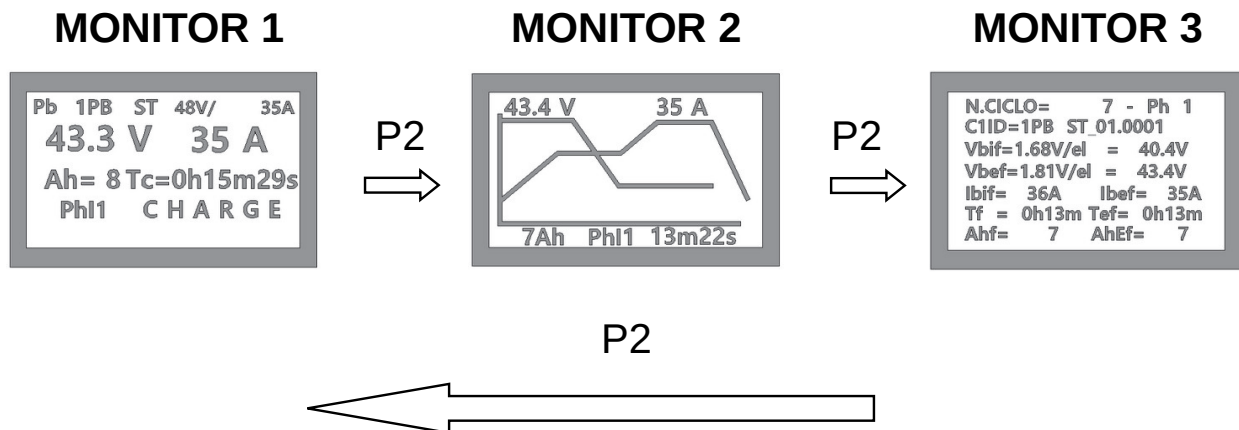

Below is a summary of the information given respectively on the 3 MONITOR displays.

MONITOR 1

LINE	EXAMPLE	DESCRIPTION
(1)	Pb 1Pb ST 48V / 35A	Battery Technology, Type of Curve, Battery Charger Rating
(2)	43,3 V 35A	Battery voltage and current
(3)	Ah= 8 Tc= 0h 15m 29s	Ah charged, Charging Time in hours, min, sec
(4)	PhI1 CHARGE	Current charging phase, battery charger STATUS
(5)	-- Messages	(e.g. phase = auto start A0, Status= BATTERY NOT CONNECTED)

MONITOR 2

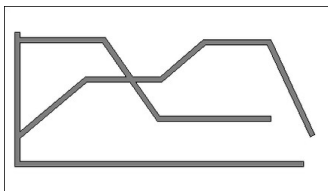
LINE	EXAMPLE	DESCRIPTION
(1)	43,3V 35A	Battery Voltage and Current Supplied
(2)		Active charge profile with indication: <ul style="list-style-type: none"> • Phases complete (thick line) • Phase in progress (flashing line) • Phases to execute (thin line)
(3)	7Ah PhI1 13m22s	Ah charged, Charging time in hours, min, sec
(4)	-- Message	Possible fault or status messages

MONITOR 3

LINE	EXAMPLE	DESCRIPTION
(1)	N.CYCLE= 7 - Ph 1	Number of charge cycle and current charge phase E.g. : charge cycle 5 and Phase 3
(2)	C1ID=1PB ST_01.0001	Charging curve unique identification
(3)	Vbif=1.68V/el = 40.4V	Battery voltage at start of phase (Vbif) expressed first as element voltage (V/el), then as absolute voltage (V)
(4)	Vbef=1.81V/el = 43.4V	Battery voltage at end of phase (current) (Vbef) expressed first as element voltage (V/el), then as absolute voltage (V)
(5)	Ibif= 36A Ibef= 35A	Current at start of phase (Ibif) and current at end of phase (Ibef)
(6)	Tf =0h13m Tef=0h13m	Single phase time (Tf) and Overall charge time at end of phase (Tef)
(7)	Ahf= 7 AhEf= 7	Ah supplied in the selected phase (Ahf) and overall charge Ah (AhEf)
(8)	-- Message	Indicates any faults occurring during the charge cycle

GUARANTEE

- The machine is guaranteed 12 months from the date of installation.
- The guarantee covers parts found to be defective in manufacturing or assembly.
- The guarantee does NOT cover damage caused by incorrect usage and/or installation.
- The guarantee lapses if any tampering is discovered.
- For any problems, please refer to an AUTHORIZED RETAILER or directly to S.P.E. Elettronica Industriale

